



Counterbalance valves

Hydraulic diagram	Type	Description	Maximum flow up		Maximum pressure		Page
			l/min	US gpm	bar	psi	
	VODL/SC/F1/C 1116	Dual counterbalance valves, line mounting	60	16	350	5100	127

Operation

The oil flow is allowed from D1 (D2) to U1 (U2) and is stopped in the opposite way from U1 (U2) to D1 (D2) up to the spring setting value. Free oil flow from U1 (U2) to D1 (D2) is strictly possible when the pilot pressure in D2 and U2 (D1 and U1) is strong enough to pilot the valve poppet.

Use the following formula to assert the applicable pilot pressure:

(valve setting - load pressure) ÷ pilot ratio = pilot pressure

For example: if your pilot ratio is 1:4, your setting pressure is 250 bar (3600 psi) and your load pressure is 130 bar (1900 psi) then you will need 30 bar (430 psi) pilot pressure in order to displace the load [(250 bar-3600 psi - 130 bar-1900 psi) ÷ 4 = 30 bar-430 psi].

Should counterpressure arise in D1 (D2), the setting value of valve poppet (1:1 ratio) will increase and the pilot pressure be negatively affected (1:1 ratio).

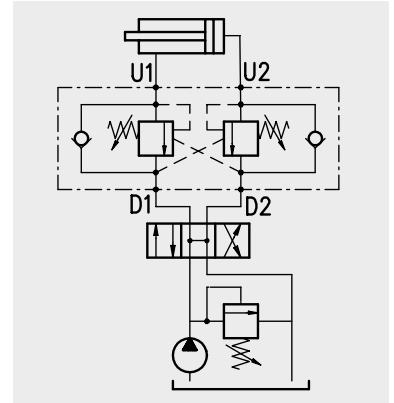

Performance

Body valves

Type	Maximum flow		Maximum pressure		Application range with standard springs	Oil leakage U1 (U2) to D1 (D2)	Pilot ratio	Weight			
	l/min	US gpm	bar	psi				kg	lb		
VODL/SC/F1/C 1116/38	30	7.9	210 (alum.)	3050 (alum.)	50÷350 bar -725÷5100 psi; pressure increase =131 bar-1900 psi/turn (test setting: 280 bar-4060 psi at 5 l/min.-1.3 US gpm)	0,25 cm ³ /min -15x10 ⁻³ in ³ /min (5 drops) at 210 bar-3050 psi and 80% of the spring setting value with oil viscosity 46 cSt.	1:4	1,1	2.42		
								aluminium			
	2,1	4.63									
	steel										
VODL/SC/F1/C 1116/12	60	16	350 (steel)	5100 (steel)						1,4	3.09
								aluminium			
					2,8	6.17					
							steel				

Type VODL/SC/F1/C 1116/38

Dual overcenter valve, line mounting. The main features of this valve are compact dimensions and good tolerance to oil contamination

Dimensions and hydraulic circuit

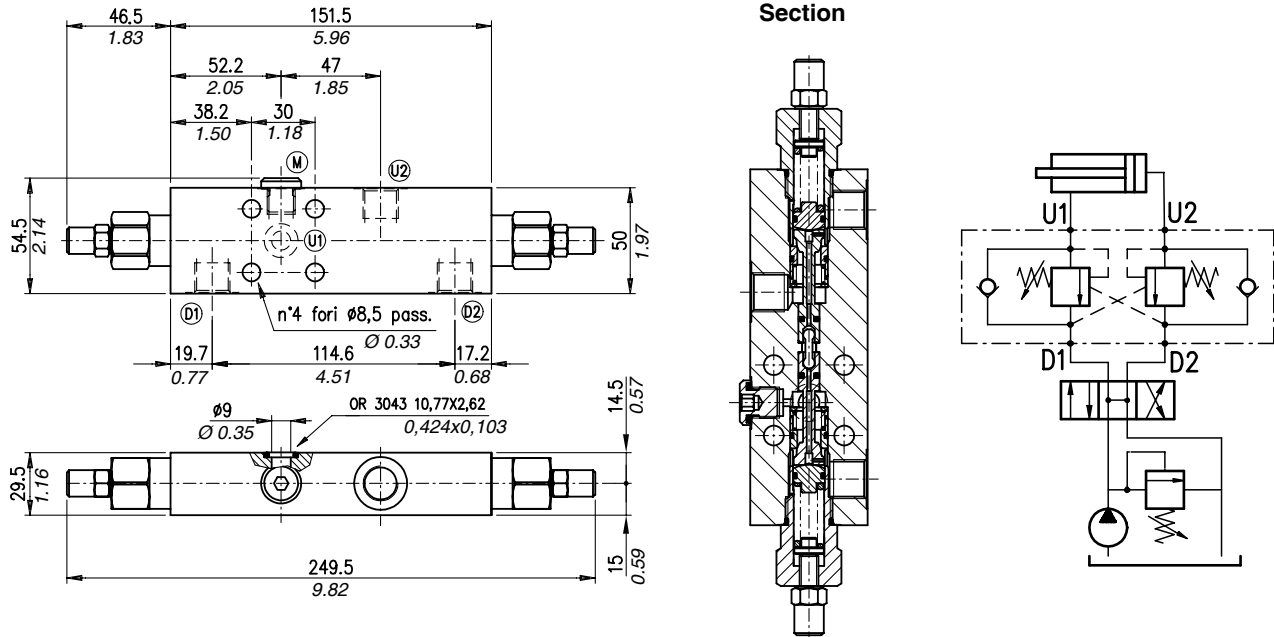

D1-D2-U2	M
G 3/8	G 1/4

Rating diagrams

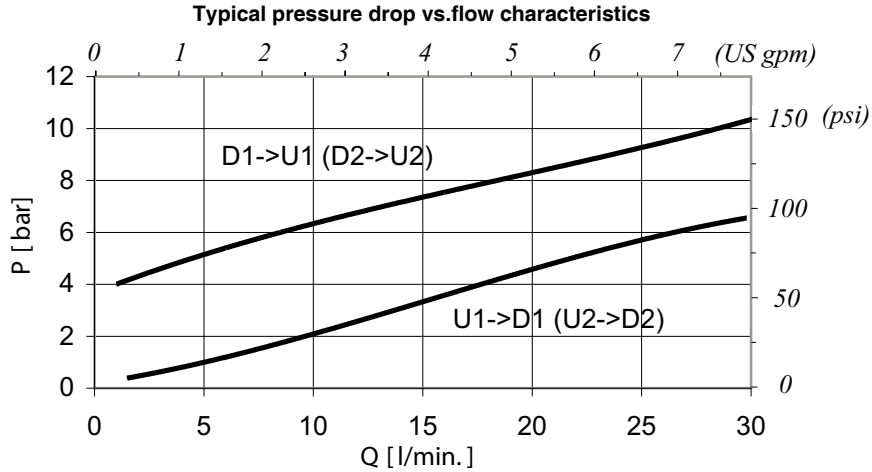

Order code

VODL /SC/F1/ C 1116/ 38 / □□ . S . □□ . / □□

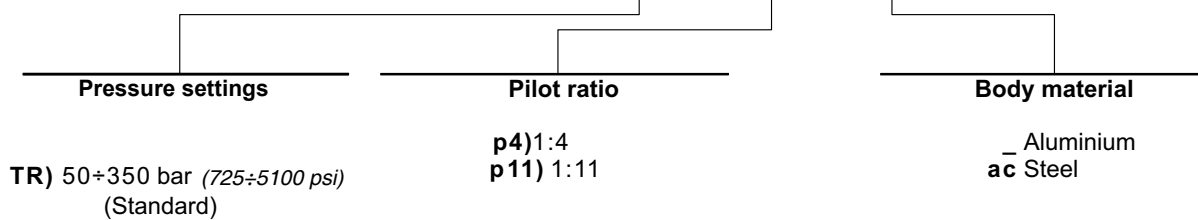

Dual overcenter valve for closed centre, line mounting.
The main features of this valve are compact dimensions
and good tolerance to oil contamination

Type VODL/SC/F1/C 1116/12

Dimensions and hydraulic circuit

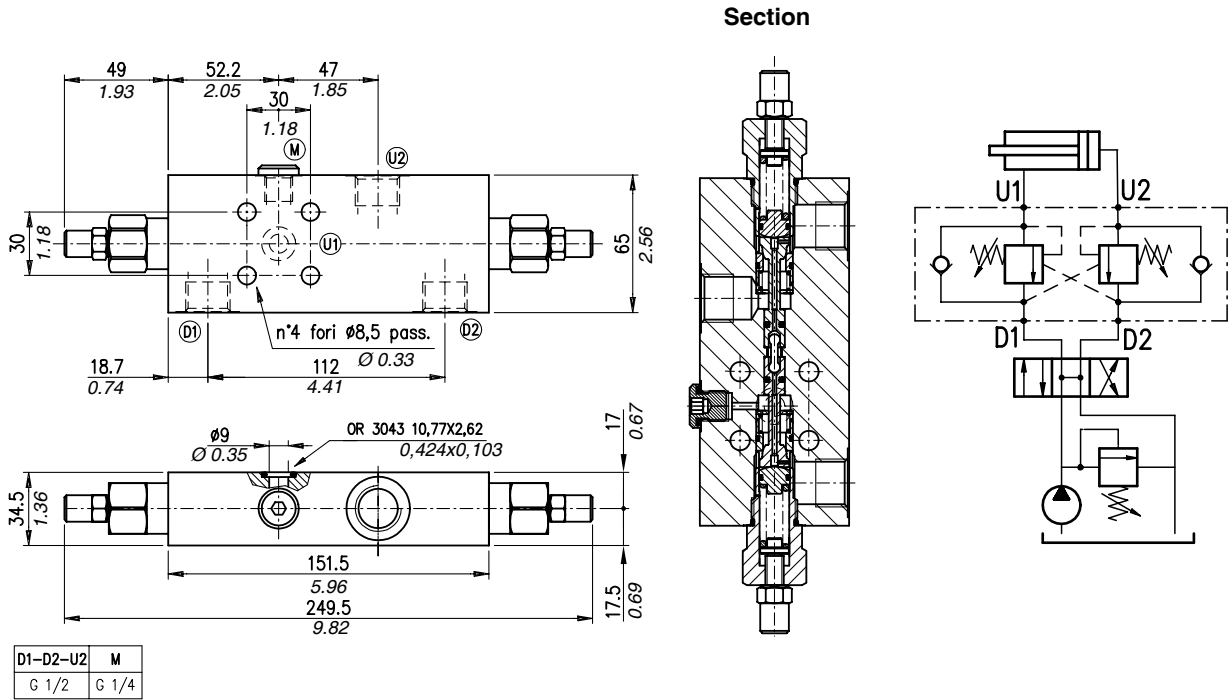

Rating diagrams

Typical pressure drop vs. flow characteristics

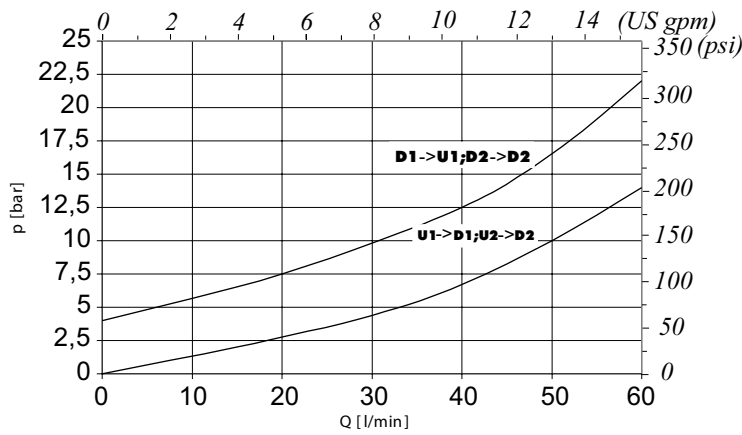

Order code

VODL /SC/F1/ C 1116/ 12 / □□ . S .□□ . / □□

Pressure settings

TR) 50÷350 bar (725÷5100 psi)
(Standard)

Pilot ratio

p4) 1:4
p11) 1:11

Body material

Aluminium
ac Steel

Material	Max. pressure	
	bar	psi
Alluminium	210	3050
Steel	350	5100

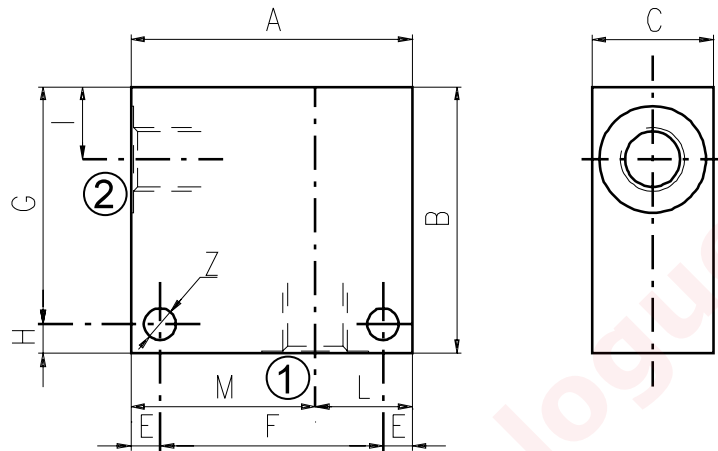

Cavity	Ports		A	B	C	E	F	G	H	I	L	M	Z
SAE 8/2	G 1/2	mm	70	65	35	7	56	53	12	14,5	35	35	6,5
		in	2.75	2.56	1.38	0.27	2.20	2.09	0.47	0.57	1.38	1.38	0.25
	G 1/4	mm	50	50	30	6	38	44	6	14,8	20	30	6,5
		in	1.97	1.97	1.18	0.24	1.50	1.73	0.24	0.58	0.79	1.18	0.25
	G 3/8	mm	50	50	30	6	38	44	6	14,8	20	30	6,5
		in	1.97	1.97	1.18	0.24	1.50	1.73	0.24	0.58	0.79	1.18	0.25
	SAE6	mm	50	50	30	6	38	44	6	14,8	20	30	6,5
		in	1.97	1.97	1.18	0.24	1.50	1.73	0.24	0.58	0.79	1.18	0.25
SAE 10/2	G 1/4	mm	60	60	35	6	48	54	6	18,8	25	35	6,5
		in	2.36	2.36	1.38	0.24	1.89	2.12	0.24	0.74	0.98	1.38	0.25
	G 3/8	mm	60	60	35	6	48	54	6	18,8	25	35	6,5
		in	2.36	2.36	1.38	0.24	1.89	2.12	0.24	0.74	0.98	1.38	0.25
	G 1/2	mm	60	60	35	6	48	54	6	18,8	25	35	6,5
		in	2.36	2.36	1.38	0.24	1.89	2.12	0.24	0.74	0.98	1.38	0.25
	SAE8	mm	60	70	35	6	48	64	6	18,8	25	35	6,5
		in	2.36	2.75	1.38	0.24	1.89	2.52	0.24	0.74	0.98	1.38	0.25
	SAE10	mm	70	70	35	6	58	64	6	18,5	35	35	6,5
		in	2.75	2.75	1.38	0.24	2.28	2.52	0.24	0.73	1.38	1.38	0.25
	SAE12	mm	70	70	40	8	54	62	8	22	30	40	8,5
		in	2.75	2.75	1.57	0.31	2.12	2.44	0.31	0.87	1.18	1.57	0.33
SAE 12/2	G 1/2	mm	70	80	40	8	54	72	8	25	30	40	8,5
		in	2.75	3.15	1.57	0.31	2.12	2.83	0.31	0.98	1.18	1.57	0.33
	G 3/4	mm	70	90	40	8	54	82	8	25	30	40	8,5
		in	2.75	3.54	1.57	0.31	2.12	3.23	0.31	0.98	1.18	1.57	0.33
	SAE10	mm	70	85	40	8	54	77	8	25	30	40	8,5
		in	2.75	3.35	1.57	0.31	2.12	3.03	0.31	0.98	1.18	1.57	0.33
	SAE12	mm	70	85	40	8	54	77	8	25	30	40	8,5
		in	2.75	3.35	1.57	0.31	2.12	3.03	0.31	0.98	1.18	1.57	0.33

Cavity	Ports	A	B	C	E	F	G	H	I	L	M	Z	
SAE 16/2	G 1/2	mm	80	90	50	10	60	80	10	25	35	45	10,5
		in	3.15	3.54	1.97	0.39	2.36	3.15	0.39	0.98	1.38	1.77	0.41
	G 3/4	mm	80	90	50	10	60	80	10	25	35	45	10,5
		in	3.15	3.54	1.97	0.39	2.36	3.15	0.39	0.98	1.38	1.77	0.41
	G 1	mm	85	100	60	10	65	90	10	23,5	40	45	10,5
		in	3.35	3.94	2.36	0.39	2.56	3.54	0.39	0.92	1.57	1.77	0.41
	SAE12	mm	80	90	50	10	60	80	10	25	35	45	10,5
		in	3.15	3.54	1.97	0.39	2.36	3.15	0.39	0.98	1.38	1.77	0.41
	SAE16	mm	80	100	50	10	60	90	10	25	35	45	10,5
		in	3.15	3.94	1.97	0.39	2.36	3.54	0.39	0.98	1.38	1.77	0.41

Order code _____

3/CC /- □ □ /20/□- □-1

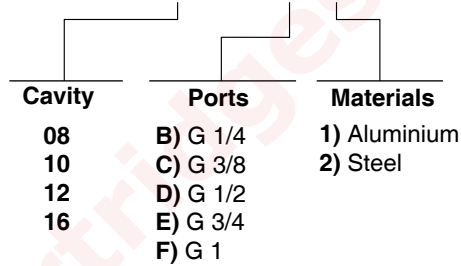

Material	Max. pressure	
	bar	psi
Alluminium	210	3050
Steel	350	5100

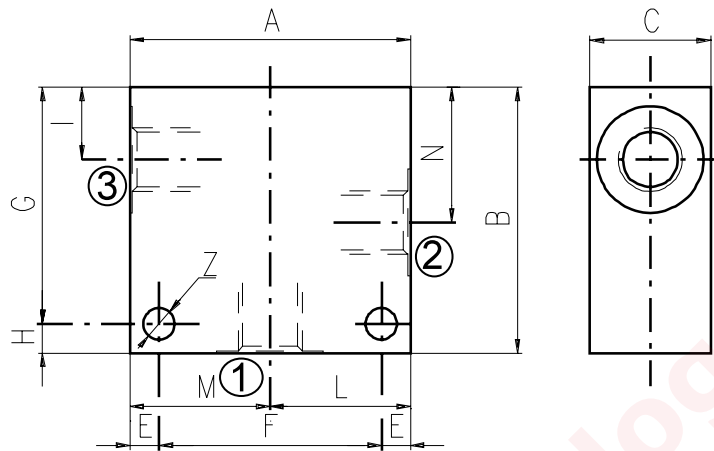

Cavity	Ports		A	B	C	E	F	G	H	I	L	M	N	Z
SAE 8/3	G 1/4	mm	60	60	30	7	46	48	12	14,8	30	30	29,1	6,5
		in	2.36	2.36	1.18	0.27	1.81	1.89	0.47	0.58	1.18	1.18	1.14	0.25
	G 3/8	mm	60	60	30	7	46	48	12	14,5	30	30	29,1	6,5
		in	2.36	2.36	1.18	0.27	1.81	1.89	0.47	0.57	1.18	1.18	1.14	0.25
	G 1/2	mm	70	65	35	7	56	53	12	14,5	35	35	29,1	6,5
		in	2.75	2.56	1.38	0.27	2.20	2.09	0.47	0.57	1.38	1.38	1.14	0.25
SAE6	mm	60	60	30	7	46	48	12	14,5	30	30	29,1	6,5	
	in	2.36	2.36	1.18	0.27	1.81	1.89	0.47	0.57	1.18	1.18	1.14	0.25	
SAE 10/3	G 1/4	mm	60	65	35	6	48	59	6	18	30	30	34,5	7
		in	2.36	2.56	1.38	0.24	1.89	2.32	0.24	0.70	1.18	1.18	1.36	0.27
	G 3/8	mm	60	65	35	6	48	59	6	18,8	30	30	34,5	7
		in	2.36	2.56	1.38	0.24	1.89	2.32	0.24	0.74	1.18	1.18	1.36	0.27
	G 1/2	mm	65	70	35	6	53	64	6	18,8	32,5	32,5	34,5	7
		in	2.56	2.75	1.38	0.24	2.09	2.52	0.24	0.74	1.28	1.28	1.36	0.27
SAE6	mm	65	70	35	6	53	64	6	18,8	32,5	32,5	34,5	7	
	in	2.56	2.75	1.38	0.24	2.09	2.52	0.24	0.74	1.28	1.28	1.36	0.27	
SAE8	mm	65	70	35	6	53	64	6	18,8	32,5	32,5	34,5	7	
	in	2.56	2.75	1.38	0.24	2.09	2.52	0.24	0.74	1.28	1.28	1.36	0.27	
SAE 12/3	G 1/2	mm	70	100	40	8	54	92	8	25	35	35	53,5	8,5
		in	2.75	3.94	1.57	0.31	2.12	3.6	0.31	0.98	1.38	1.38	2.10	0.33
	G 3/4	mm	90	100	50	10	70	90	10	25,1	45	45	53,5	10,5
		in	3.54	3.94	1.97	0.39	2.75	3.54	0.39	0.99	1.77	1.77	2.11	0.41
	SAE10	mm	80	100	40	8	64	92	8	25	40	40	53,5	8,5
		in	3.15	3.94	1.57	0.31	2.52	3.6	0.31	0.98	1.57	1.57	2.11	0.33
SAE12	mm	80	100	45	8	64	92	8	25	40	40	53,5	8,5	
	in	3.15	3.94	1.77	0.31	2.52	3.6	0.31	0.98	1.57	1.57	2.11	0.33	

Cavity	Ports	A	B	C	E	F	G	H	I	L	M	N	Z	
SAE 16/3	G 3/4	mm	90	100	50	10	70	90	10	25,1	45	45	53,5	10,5
		in	3.54	3.94	1.97	0.39	2.75	3.54	0.39	0.99	1.77	1.77	2.11	0.41
	SAE12	mm	90	105	50	10	70	95	10	25,1	45	45	53,5	10,5
		in	3.54	4.13	1.97	0.39	2.75	3.74	0.39	0.99	1.77	1.77	2.11	0.41
	SAE16	mm	90	105	50	10	70	95	10	25,1	45	45	53,5	10,5
		in	3.54	4.13	1.97	0.39	2.75	3.74	0.39	0.99	1.77	1.77	2.11	0.41

Order code _____

3/CC /- □ □ /30/□- □-1

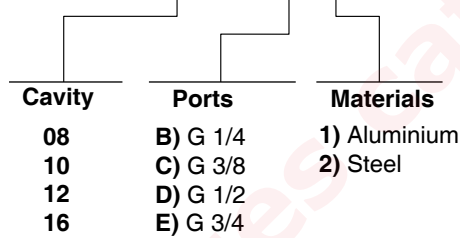

Material	Max. pressure	
	bar	psi
Alluminium	210	3050
Steel	350	5100

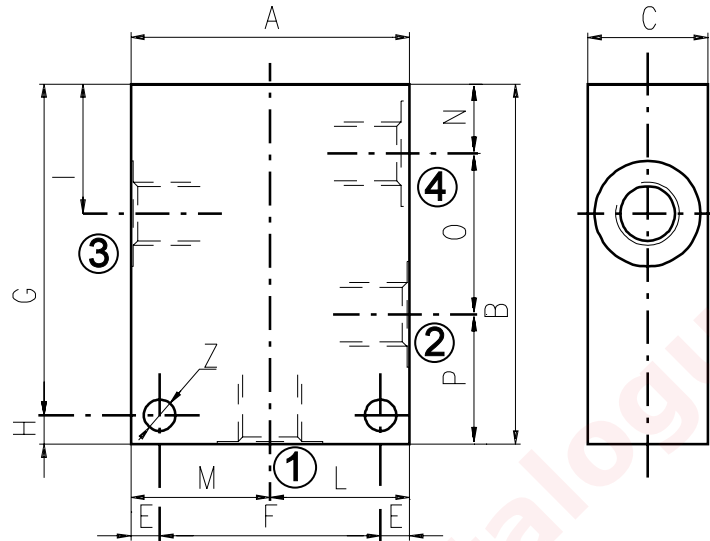

Cavity	Ports		A	B	C	E	F	G	H	I	L	M	N	O	P	Z
SAE 8/4	G 1/4	mm	60	75	30	7	46	63	12	29,1	30	30	14,8	29,1	31,1	6,5
		in	2.36	2.95	1.18	0.27	1.81	2.48	0.47	1.14	1.18	1.18	0.58	1.14	1.22	0.25
	SAE6	mm	60	75	30	7	46	63	12	29,1	30	30	14,8	29,1	31,1	6,5
		in	2.36	2.95	1.18	0.27	1.81	2.48	0.47	1.14	1.18	1.18	0.58	1.14	1.22	0.25
SAE 10/4	G 3/8	mm	60	85	35	6	48	79	6	34,5	30	30	18,8	31,7	34,5	7
		in	2.36	3.35	1.38	0.24	1.89	3.11	0.24	1.36	1.18	1.18	0.74	1.25	1.36	0.27
	G 1/2	mm	70	85	35	6	58	79	6	34,5	35	35	18,8	31,7	34,5	7
		in	2.75	3.35	1.38	0.24	2.28	3.11	0.24	1.36	1.38	1.38	0.74	1.25	1.36	0.27
	SAE6	mm	60	85	35	6	48	79	6	34,5	30	30	18,8	31,7	34,5	7
		in	2.36	3.35	1.38	0.24	1.89	3.11	0.24	1.36	1.18	1.18	0.74	1.25	1.36	0.27
SAE8	mm	70	85	35	6	58	79	6	34,5	35	35	18,8	31,7	34,5	7	
	in	2.75	3.35	1.38	0.24	2.28	3.11	0.24	1.36	1.38	1.38	0.74	1.25	1.36	0.27	
SAE 12/4	G 1/2	mm	80	115	40	8	64	107	8	44	40	40	22	44,5	48,5	8,5
		in	3.15	4.53	1.57	0.31	2.52	4.21	0.31	1.73	1.57	1.57	0.87	1.75	1.9	0.33
	SAE10	mm	80	115	40	8	64	107	8	44	40	40	22	44,5	48,5	8,5
		in	3.15	4.53	1.57	0.31	2.52	4.21	0.31	1.73	1.57	1.57	0.87	1.75	1.9	0.33
SAE 16/4	G 3/4	mm	100	130	50	10	80	120	10	53,5	50	50	25,1	56,9	48	10,5
		in	3.94	5.12	1.97	0.39	3.15	4.72	0.39	2.11	1.97	1.97	0.99	2.24	1.89	0.41

Order code

3/CC /- □ □ /40/□- □-1

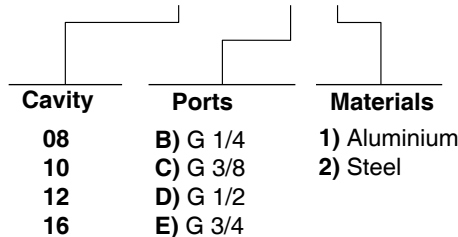

Informations

How to order valves with body

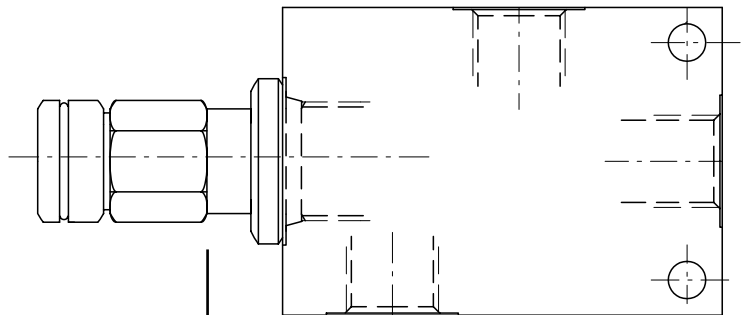

CARTRIDGE CODE

BILLET CODE

CC-12-A/9-S-2B/

D- 1-1

Cavity	Ports	Materials
08	B) G 1/4	1) Aluminium
10	C) G 3/8	
12	D) G 1/2	
16	E) G 3/4	
	F) G 1	
	J) SAE 6	2) Steel
	K) SAE 8	
	L) SAE 10	
	M) SAE 12	
	N) SAE 16	

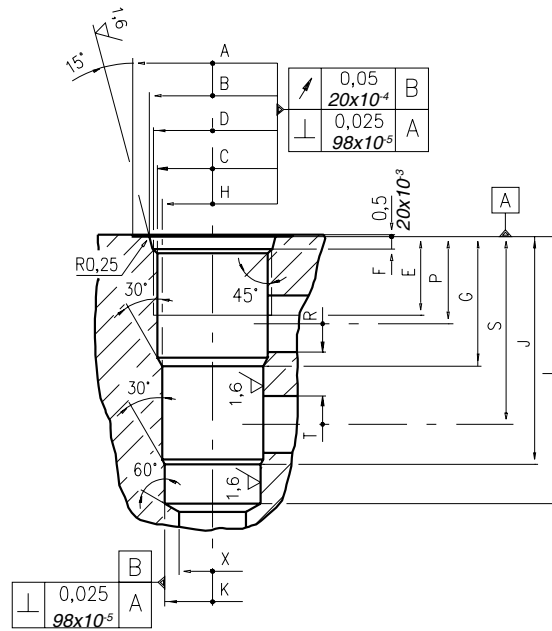

\	A	B ±0,05	C ±0,05	D	E	F	G	H ±0,02	J	K ±0,02	L	M ±0,02	N	P	R øMAX	S	T øMAX	U	V øMAX	X øMAX	Z øMIN	Prof. Z MIN	
08/3	mm	27	20,66	17,42	3/4-16 UNF	12,50	2,5	19,10	15,90	33,30	14,30	43,30	-	-	14,30	5,50	28,60	5,50	-	-	12,50	-	-
	in	1.06	0.81	0.68		0.49	0.10	0.75	0.62	1.31	0.56	1.70			0.56	0.22	1.12	0.22			0.49		
10/3	mm	30	24,00	20,62	7/8-14 UNF	16,00	2,80	23,10	17,50	39,60	15,90	47,60	-	-	18,30	6,50	34,00	6,50	-	-	14,00	-	-
	in	1.18	0.94	0.81		0.63	0.11	0.94	0.69	1.56	0.62	1.87			0.72	0.25	1.34	0.25			0.55		
12/3	mm	38	29,23	24,73	1 1/16-12 UNF	19,00	3,56	36,60	23,82	63,50	22,25	75,40	-	-	24,50	16,00	53,00	16,00	-	-	19,00	-	-
	in	1.50	1.15	0.97		0.75	0.14	1.44	0.94	2.5	0.88	2.97			0.96	0.63	2.09	0.63			0.75		
16/3	mm	45	35,6	31,34	1 5/16-12 UNF	22,00	3,5	36,50	28,62	64,30	27,02	75,38	-	-	24,60	16,00	53,00	16,00	-	-	19,00	-	-
	in	1.77	1.40	1.23		0.87	0.14	1.44	1.13	2.53	1.06	2.97			0.97	0.63	2.09	0.63			0.75		

Cavity plugs

Rougher tool

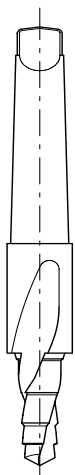

Finisher tool

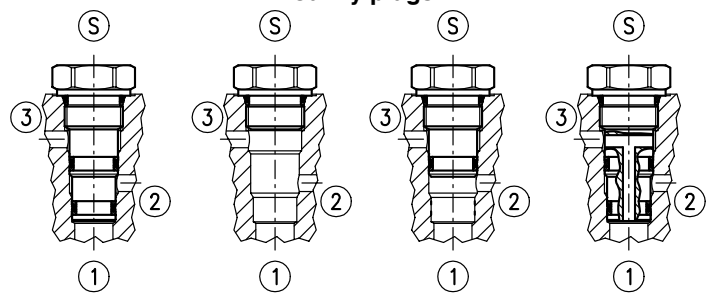

Tap

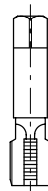

Cavity	Code number
08/3	3UT00052190
10/3	3UT00054170
12/3	3UT00054290
16/3	3UT00054470

Cavity	Code number
08/3	3UT00052740
10/3	3UT00054180
12/3	3UT00054300
16/3	3UT00054480

Cavity	Code number
08/3	3UT03416UNF
10/3	3UT07814UNF
12/3	3UT0111612UN
16/3	3UT0151612UN

Dimensions

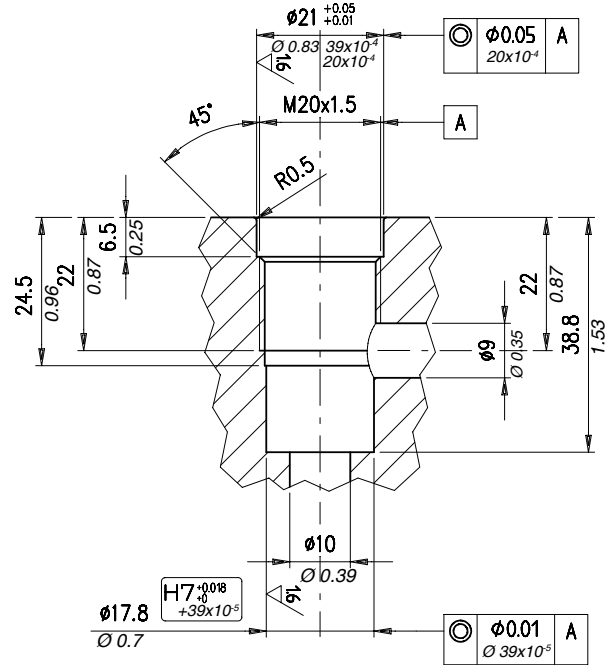

Rougher tool

Cod.3UT00050050

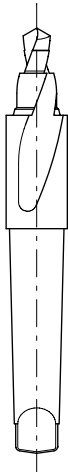

Finisher

Cod.3UT00055040



Tap

Cod.3UT08A20F150



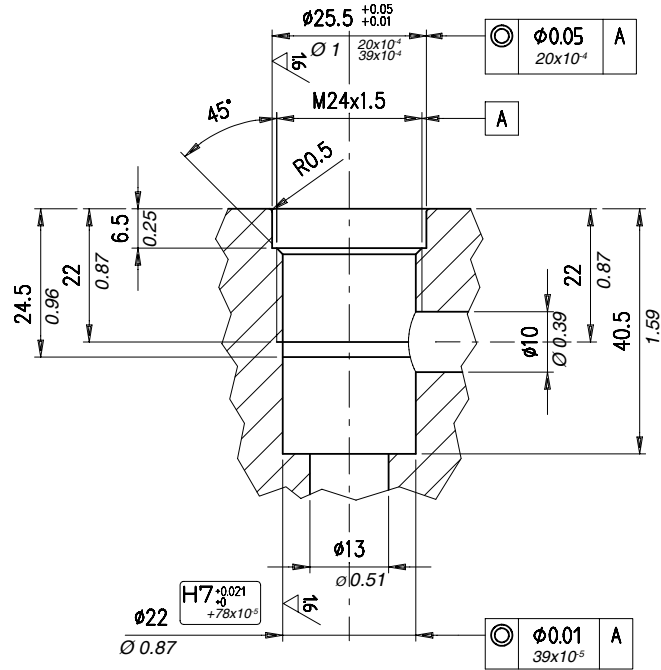

Rougher tool
Cod.3UT00050070

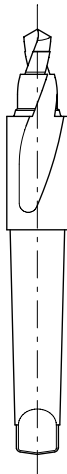

Finisher
Cod.3UT06A22000P



Tap
Cod.3UT08A24F150



Dimensions

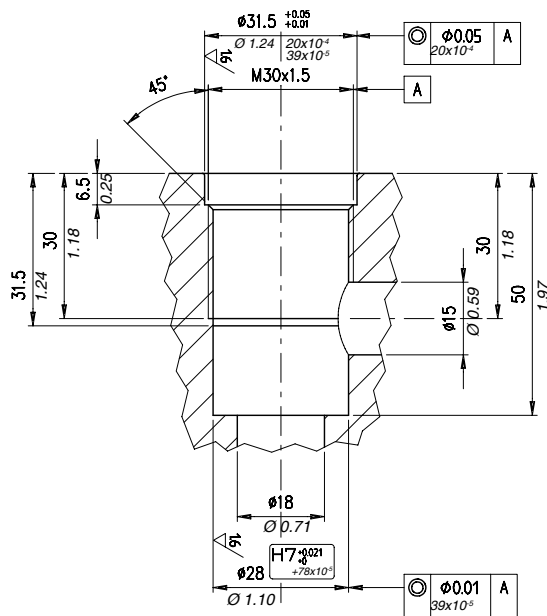

Rougher tool
Cod.3UT00050100

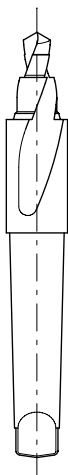

Finisher
Cod.3UT06A2800P



Tap
Cod.3UT08A30F150

